

Installation Instructions

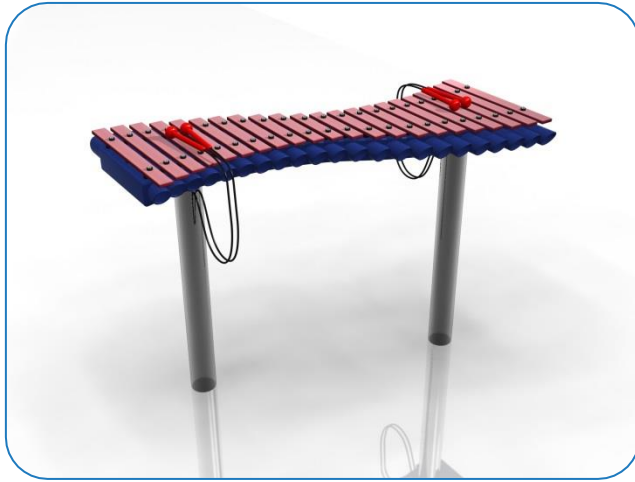

1. Attach the steel legs to the base of the instrument with the M8x25 security screws and lock washers. (1.1) (See Assembly Guide)

2. Attach Ground Fixing posts to legs (1.2) (See Ground Fix Post Installation Sheet)

3. Excavate 2 holes for the Steel legs 200mm diameter by 400-550mm deep depending on Key stage, in desired location upon decision from customer.

4. Locate (lower) legs into holes making sure they are vertical and level prior to concreting in place.

5. Once happy with location of the Instrument, fill holes using rapid hardening concrete. Be sure to compact concrete around legs and leave to dry according to manufactures guidelines.

6. Attach the 1 pair of beater to the saddle strap on the leg. (1.3)

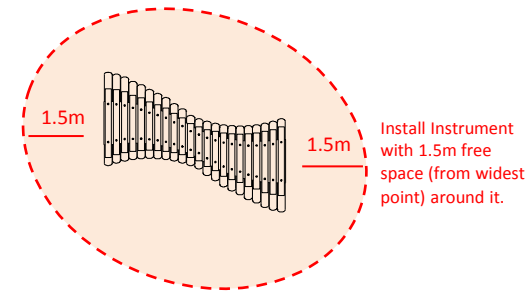

Weight of heaviest part 14kg (Duo)

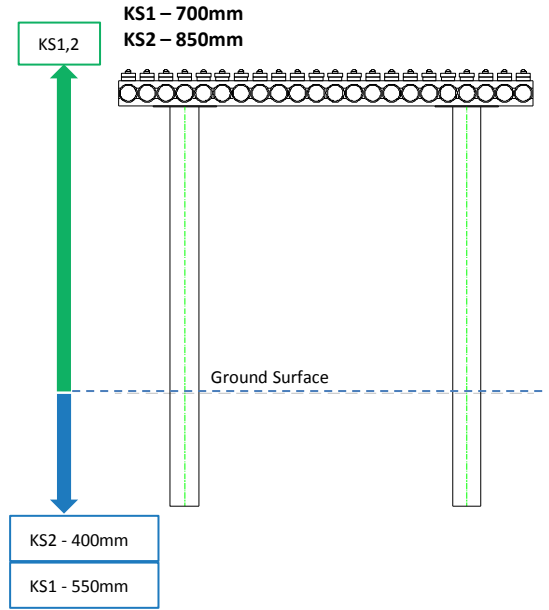

Ground Fixed
Duo
Page 1 of 3





Instrument Components:

-  x8
-  x4
-  x8
-  x2
-  x2



Ground Fix Components:



-  x4
-  x8

Spares available form
percussionplay.co.uk or from
your local distributor

20 Kg

Assembly Guide PPDUO

Tools:

-  x1
-  x1
-  x1



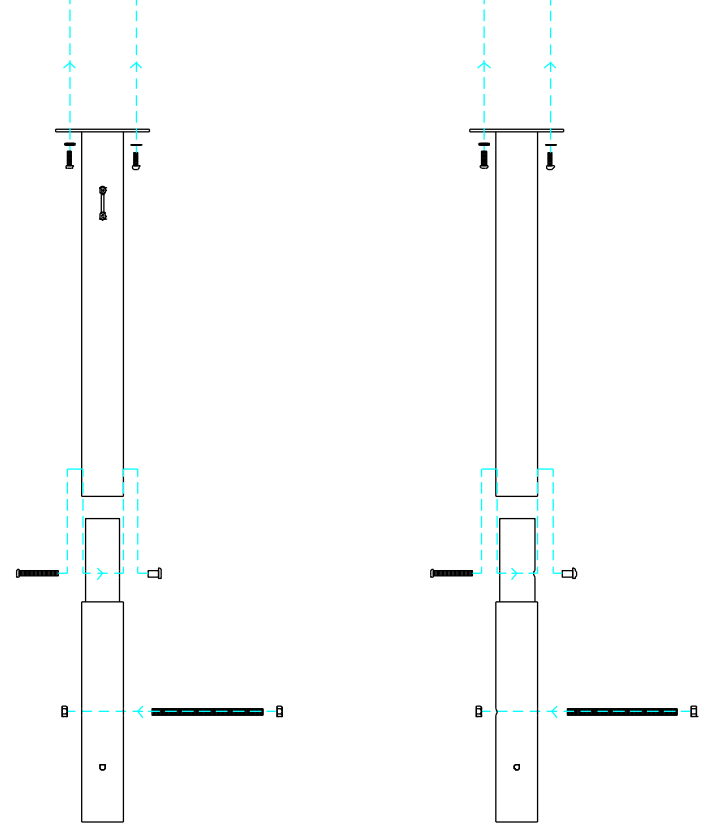
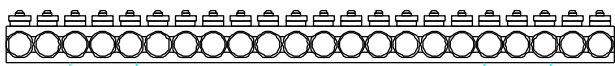





Ground Fixed
Duo
Page 2 of 3



PPDUO FRONT

PPDUO SIDE

COMPONENTS LIST:

-  M8x25 Pin torx X8
-  M8 Lock washer X8
-  M10 Nut X8
-  M10x200 Threaded Bar X4
-  Saddle Strap X2
-  M6x20 Pin torx X4
-  M10x70 Pin torx X2
-  M10 Barrel Nut Pin torx X2

Instrument Components:

-  x8
-  x4
-  x8
-  x2



Pair Small Red Beaters X2

Ground Fix Components:

-  x4
-  x8
-  x2
-  x2

Spares available from
percussionplay.co.uk or from
your local distributor

20 Kg

Ground Fix Post Installation

Tools:

 x1
TX 45 Driver Bit

Ground Fixed
Duo
Page 3 of 3

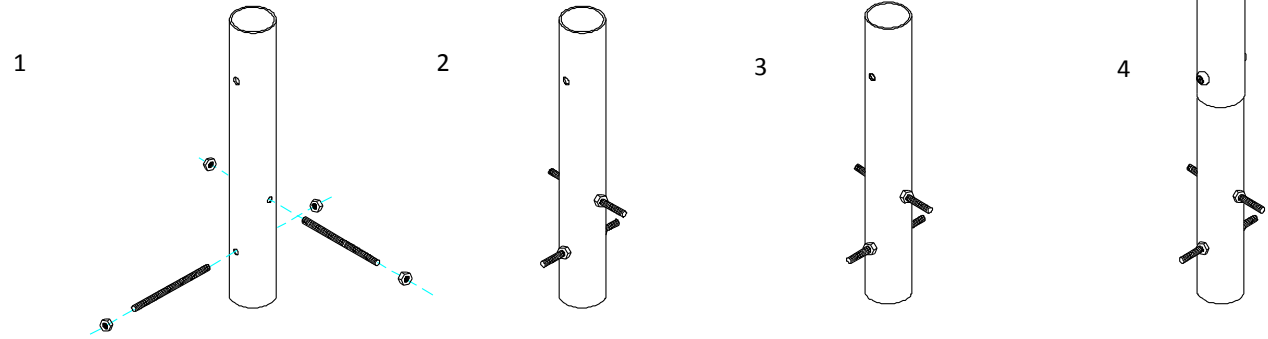

1 Insert M10x 200 Threaded bar into pre drilled holes in Ground Fixing Post

2 Fix M10x 200 Threaded bar in place using M10 Nuts

3 Locate the Ground fix Post into the leg of the instrument.

4 Fix instrument to Ground fix post using M10 bolt and Barrel Nut and use **thread locking solution** to prevent fixings working loose.

Components:

-  x4
- M10x200 Bolt
-  x8
- M10 Nut
-  x2
- M10 Barrel Nut
-  x2
- M10x70 Security Screw

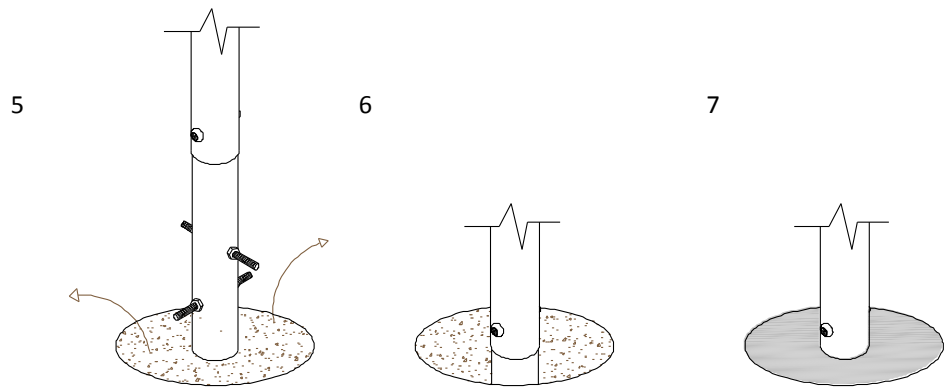

5 Excavate 6 holes with a 250mm diameter tapering down to 350mm diameter and 450mm depth

400mm min depth

6 Compact base of hole with 50mm of aggregate. Lower ground Fix post attached to instrument into hole (check instrument straight and level before filling with concrete)

7 Fill hole with fast drying concrete to manufacturers specifications.

Duplicate points 1-7. Duo requires 2 Ground Fix Posts

