

Installation Instructions

Ground Fixed Calypso Chimes Page 1 of 4



Weight of heaviest part 7.5kg

1. Instrument will arrive on site fully assembled. **(1.1)**
(See Assembly Guide)

2. Attach Ground Fixing studs holes in base of centre post **(1.2)** (See Ground Fix Post Installation Sheet)

3. Excavate **1 hole** for the Steel legs **250mm diameter** by **450mm deep** in desired location upon decision from customer.

4. Locate (lower) leg into hole, making sure it is vertical and level prior to concreting in place.

5. Once happy with location of the Instrument, **fill** holes using rapid hardening **concrete**. Be sure to compact concrete around legs and leave to dry according to manufacturers guidelines.

6. Attach the holder, beater and the saddle strap on each side of the post. **(1.3)**

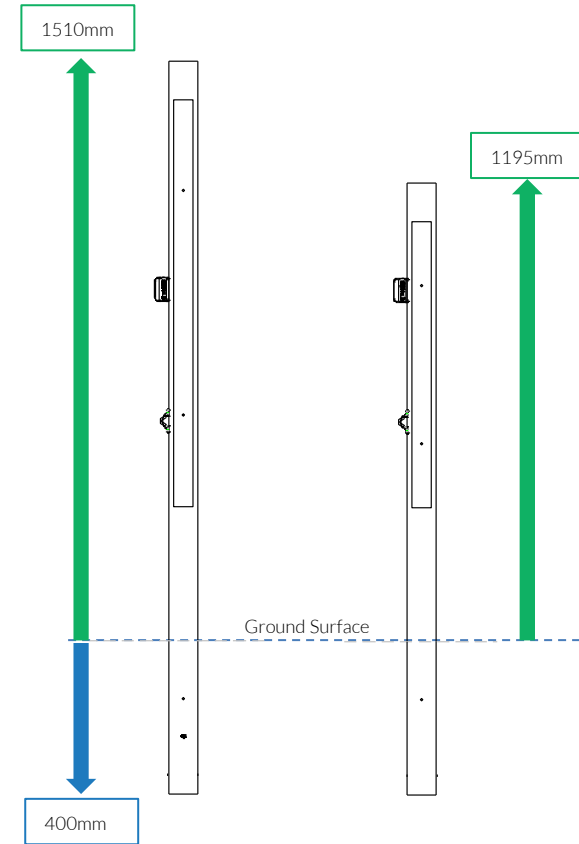
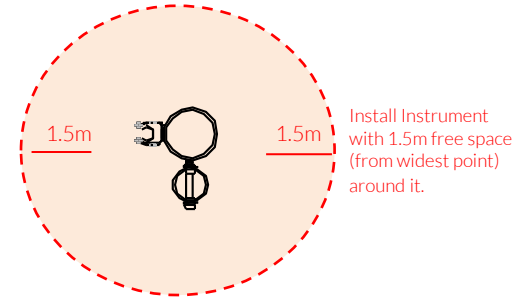

Instrument Components Per Post:

-  x4
M6x20 Security Screw
-  x1
M6 Saddle Strap
-  x2
M6 Square Nut
-  x1
Beater Holder

Metric Conversion:
250mm/ 10"
400mm/ 16"
450mm/ 18"
1510mm/ 59"
1195mm/ 47 3/64"
1.5m/ 59"



Ground Fix Components Per Post:

-  x2
M10x200 Threaded Bar
-  x4
M10 Nut



Spares available from percussionplay.com or from your local distributor

8 Kg

Tools:



x1
TX 30 Driver Bit

Ground Fixed
Calypso Chimes
Page 2 of 4



Instrument
Components Per Post:

-  x4
M6x20 Security Screw
-  x1
M6 Saddle Strap
-  x2
M6 Square Nut
-  x1
Beater Holder

Thread Lock Solution
Required (Not Supplied)





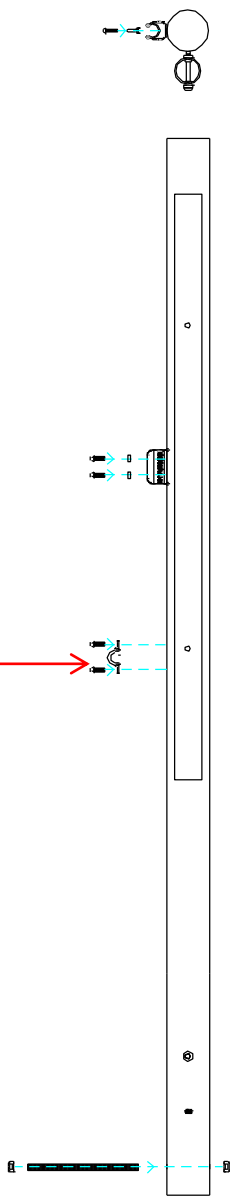

Single Small Red
Beaters X1

Ground Fix
Components Per Post:

-  x2
M10x200 Threaded Bar
-  x4
M10 Nut



COMPONENTS LIST:

-  M10 Nut X4
-  M10x200 Threaded Bar X2
-  Saddle Strap X2
-  M6x20 Pin torx X4
-  M6 Square Nut X2
-  Beater Holder X1



Spares available from
percussionplay.com or from your
local distributor

8 Kg

Ground Fixed
Calypso Chimes
Page 3 of 4





Instrument
Components Per Post:

-  x4
M6x20 Security Screw
-  x1
M6 Saddle Strap
-  x2
M6 Square Nut
-  x1
Beater Holder

600mm min spacing

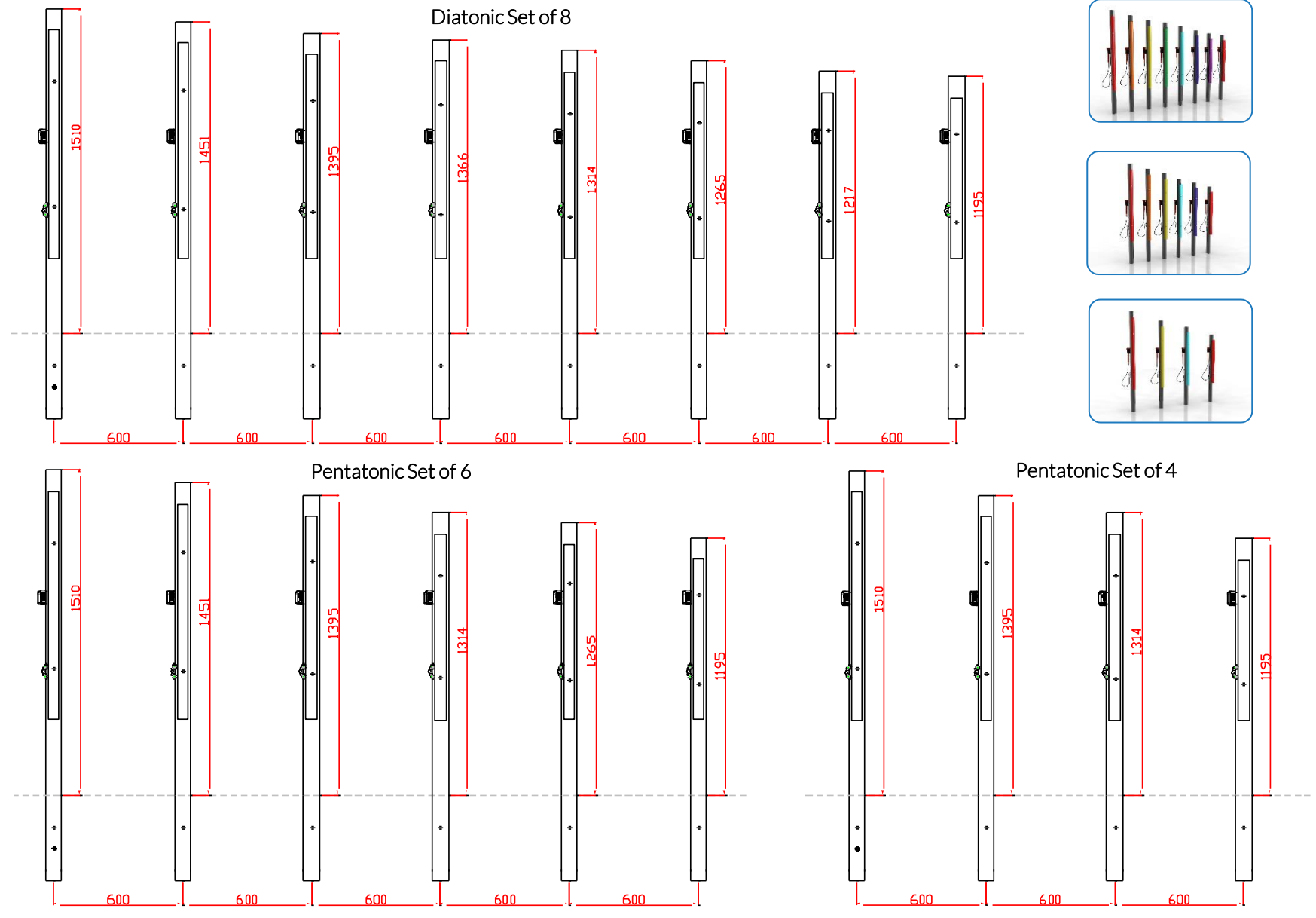
Thread Lock Solution
Required (Not Supplied)



 Single Small Red Beaters X1

Ground Fix
Components Per Post:

-  x2
M10x200 Threaded Bar
-  x4
M10 Nut



Spares available from
percussionplay.com or from your
local distributor

8 Kg

Ground Fixed
Calypso Chimes
Page 4 of 4



Instrument Components Per Post:

 x2
M10x200 Threaded Bar

 x4
M10 Nut

Metric Conversion:
50mm/ 2"
250mm/ 10"
350mm/ 14"
400mm/ 16"
450mm/ 18"



MADE IN BRITAIN

BSEN 1176

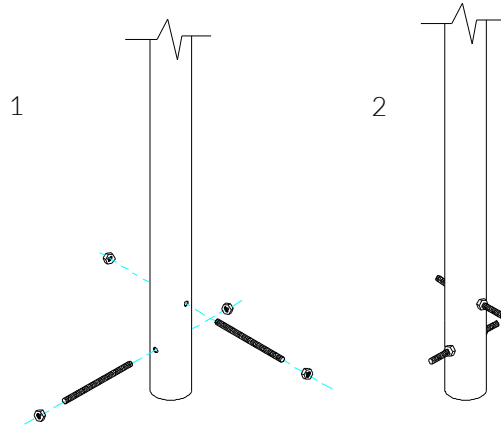

Fix M10x 200 Threaded bar in place using M10 Nuts

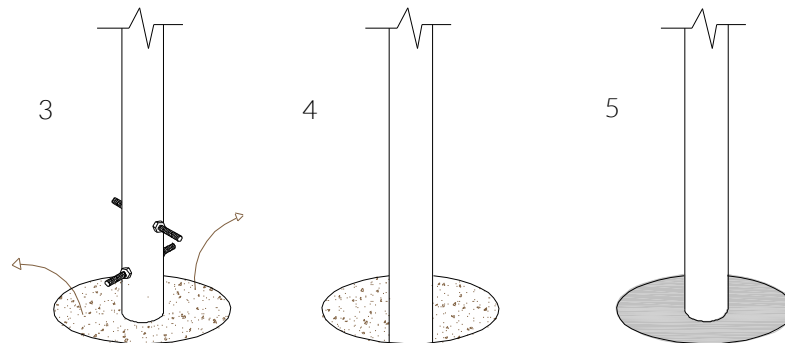

Excavate 1 holes with a 250mm diameter tapering down to 350mm diameter and 450mm depth

Compact base of hole with 50mm of aggregate. Lower ground Fix post attached to instrument into hole (check instrument straight and level before filling with concrete)

Fix hole with fast drying concrete to manufacturers specifications.

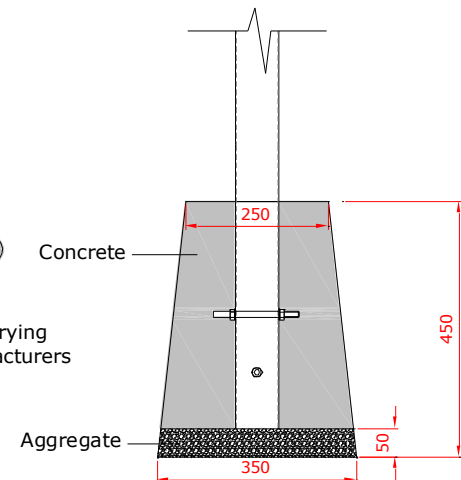

400mm min depth

