

Installation Instructions

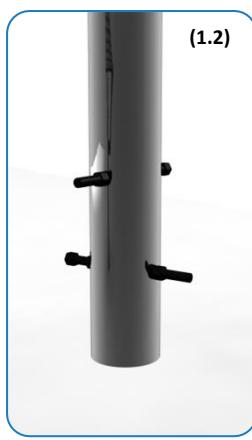
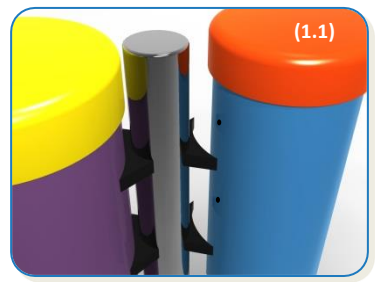

1. Attach the steel leg to each of the congas with the M10x30 security screws, square washers and HDPE mounts. **(1.1)** (See Assembly Guide)

2. Attach Ground Fixing posts to legs **(1.2)** (See Ground Fix Post Installation Sheet)

3. Excavate **1 hole** for the Steel leg **200mm diameter by 400mm deep**, in desired location upon decision from customer.

4. Locate (lower) legs into hole making sure they are vertical and level prior to concreting in place.

5. Once happy with location of the Instrument, **fill hole** using rapid hardening **concrete**. Be sure to compact concrete around legs and leave to dry according to manufactures guidelines.

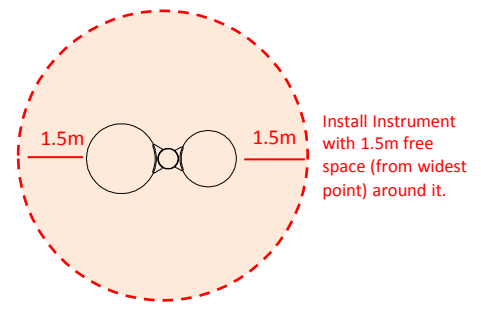

Small – 600mm
Medium – 700mm
Large- 800mm

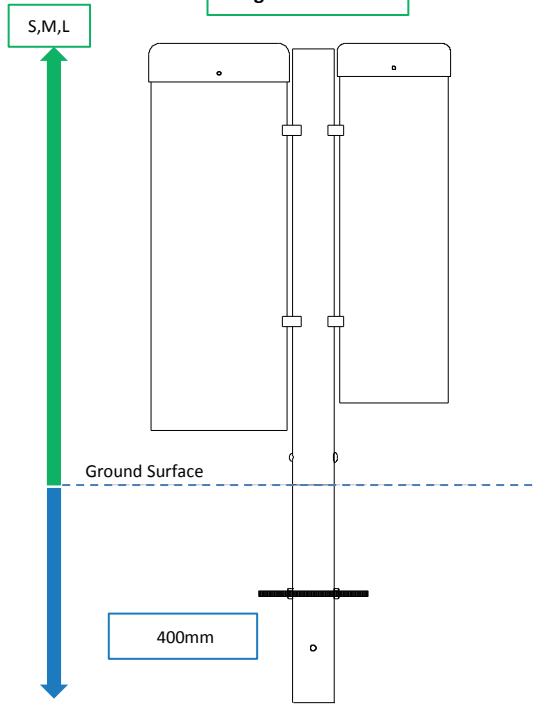





Weight of heaviest part **3.8kg** (Large drum Small Congas)
Weight of heaviest part **4.5kg** (Large drum Medium Congas)
Weight of heaviest part **5.2kg** (Large drum Large Congas)

Ground Fixed
Congas
Page 1 of 3



Instrument Components:

-  x4
- M10x30 Security Screw
-  x4
- M10x50x3 Square washer
-  x2
- 200 Mount
-  x2
- 250 Mount



Ground Fix Components:

-  x2
- M10x200 Bolt
-  x4
- M10 Nut
-  x1
- M10x70 Security Screw
-  x1
- M10 Barrel Nut

Spares available form percussionplay.co.uk or from your local distributor

10 Kg
15 Kg
20 Kg

Tools:



x1
TX 45 Driver Bit

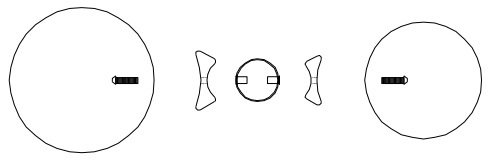

PPCONG PLAN

Ground Fixed
Duo
Page 2 of 3

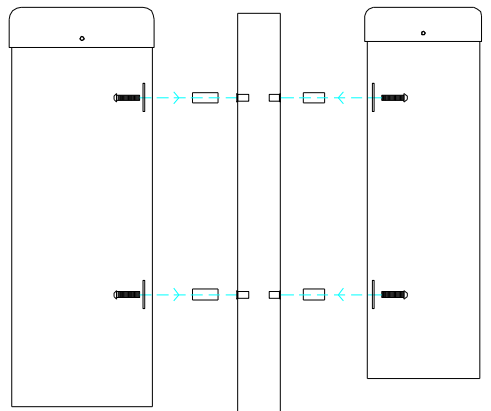



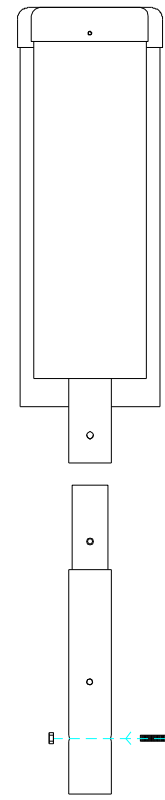





PPCONG FRONT







PPCONG SIDE

COMPONENTS LIST:

-  M10x30 Pin torx X4
-  M10x50x3 square washer X4
-  M10 Nut X4
-  M10x200 Threaded Bar X2
-  HDPE MOUNT 200 X2
-  HDPE MOUNT 250 X2
-  M10x70 Pin torx X1
-  M10 Barrel Nut Pin torx X1

Instrument Components:

-  x4
M10x30 Security Screw
-  x4
M10x50x3 Square washer
-  x2
200 Mount
-  x2
250 Mount



Played with hands

Ground Fix Components:

-  x2
M10x200 Bolt
-  x4
M10 Nut
-  x1
M10x70 Security Screw
-  x1
M10 Barrel Nut

Spares available from
percussionplay.co.uk or from
your local distributor

10 Kg
15 Kg
20 Kg

Ground Fix Post Installation

Tools:

- x1 TX 45 Driver Bit

Ground Fixed
Congas
Page 3 of 3

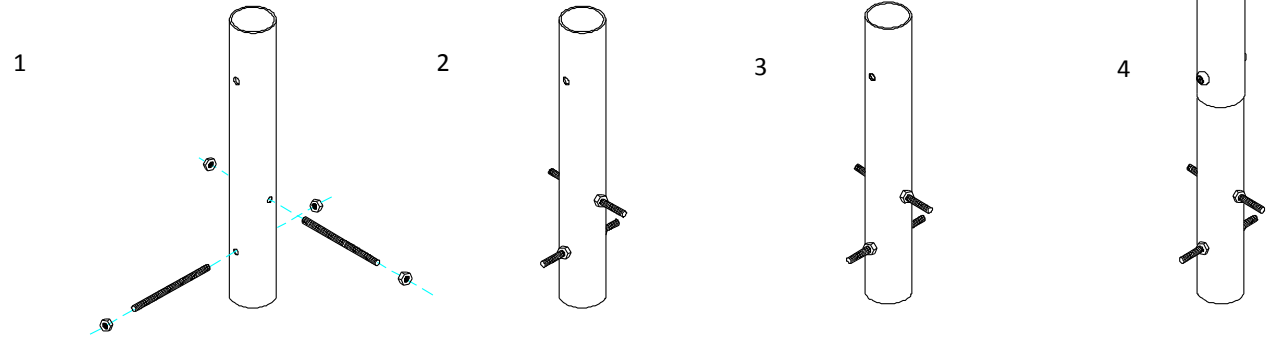

1 Insert M10x 200 Threaded bar into pre drilled holes in Ground Fixing Post

2 Fix M10x 200 Threaded bar in place using M10 Nuts

3 Locate the Ground fix Post into the leg of the instrument.

4 Fix instrument to Ground fix post using M10 bolt and Barrel Nut and use **thread locking solution** to prevent fixings working loose.

Components:

- x2 M10x200 Bolt
- x4 M10 Nut
- x1 M10 Barrel Nut
- x1 M10x70 Security Screw

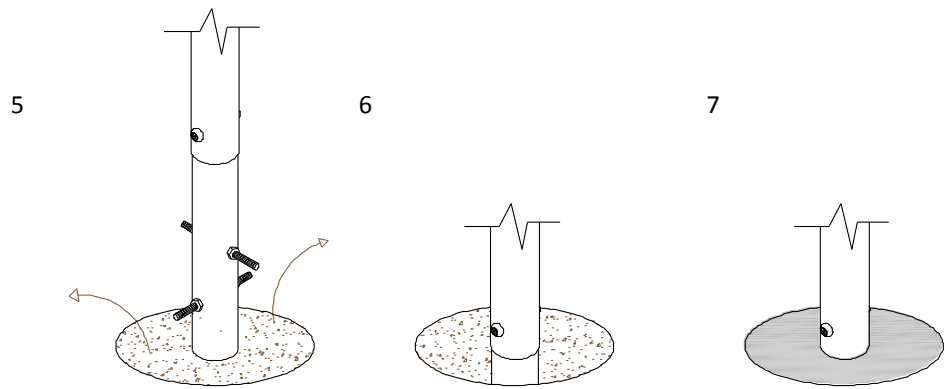

5 Excavate 6 holes with a 250mm diameter tapering down to 350mm diameter and 450mm depth

6 Compact base of hole with 50mm of aggregate. Lower ground Fix post attached to instrument into hole (check instrument straight and level before filling with concrete)

7 Fill hole with fast drying concrete to manufacturers specifications.

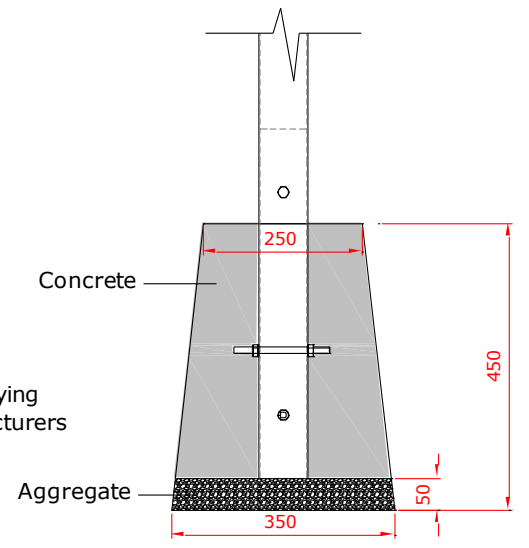

400mm min depth